



Concept for Automation of Test Rig for Metals Recovery from Municipality Waste Incinerator Ashes

علي ابراهيم ، علي عواد، وليد نعوس، وسيم الحاج

مشرف: د. سمير مراد

Last update: Monday, July 06, 2020

CHAPTER 1. TASK	2
CHAPTER 2. BASICS	2
CHAPTER 3. HEAVY METALS TEST RIG DESIGN	4
CHAPTER 4. ACTUAL REALIZATION	6
CHAPTER 5. LIST OF SENSORS AND ACTUATOR	10
CHAPTER 6. AUTOMATION	11

CHAPTER 1. TASK

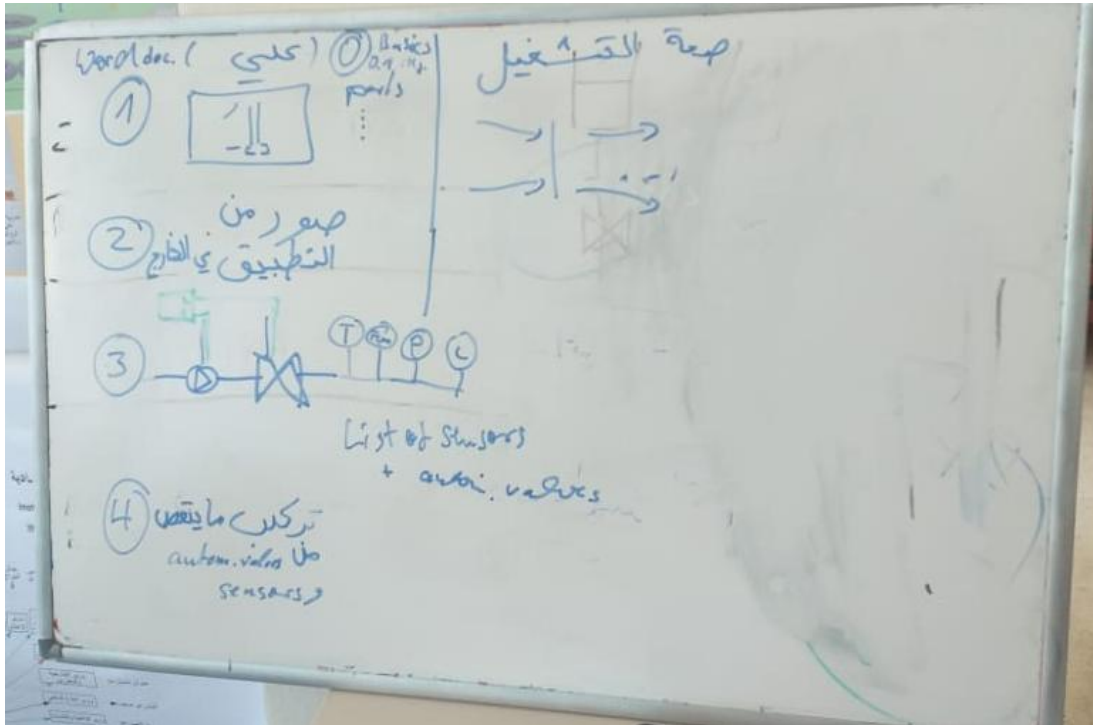

CHAPTER 2. BASICS

- Open the pump and reach the column with 44 L of ash mixed with nitric acid
- When the liquid level in the column reaches the top right nozzle (turn the feed flowrate down to the desired set point
- Turn on and set the extractant flowrate to the desired set point by adjusting the pump speed
- Close the extract out rotameter when the liquid level reaches the top left (extract out) nozzle.

- Allow the interface to form between the top mesh and the top left nozzle (extract out). The interface appears as an immiscible layer between acid and extractant with droplets.
- Once the interface is formed in the desired location, open the extract out rotameter slowly until there are flowrates out of the column.
- Adjusting this rotameter is used to control the interface level. Opening the rotameter causes the interface to rise, while closing it causes the interface to drop.
- The optimum setting of this rotameter will allow for a semi-stable interface and give a minimal amount of drift in the interface level.
- Small adjustments should be made in order to keep the interface constant.
- Set the stirrer speed to a setting of 5 using the dial on the top right of the lab equipment panel. Make sure the motor is powered with the top center switch on the right power panel.
- Allow the column to run until steady state is achieved (about hour).

CHAPTER 3. HEAVY METALS TEST RIG

DESIGN

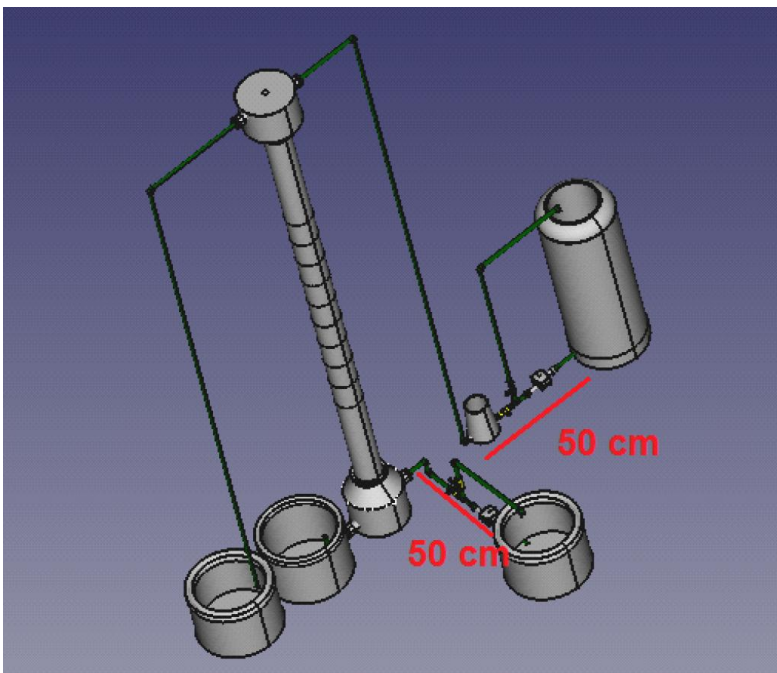
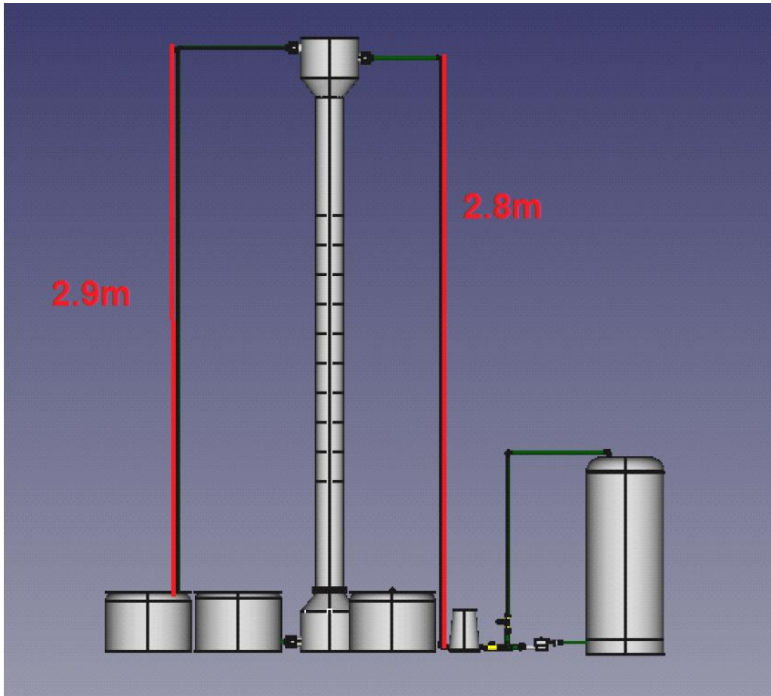

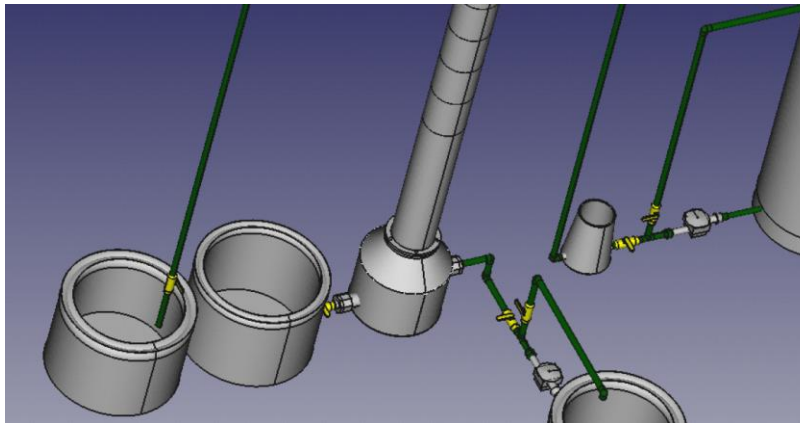
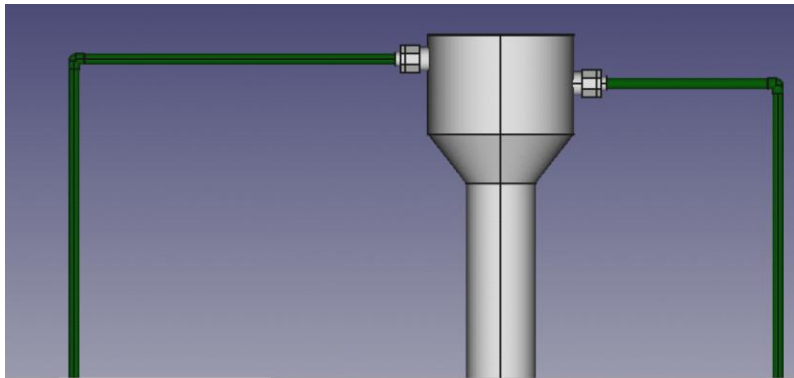

parts needed:

- 4 valve
- 4 pipes (4m each)
- 3 medium sized tanks
- 2 electrical pumps (> 1hp)
- 4 moukhalef + wasel zira3e
- 9 turnes 90 ppr
- 2 tees ppr

initial cost: ~ 200 \$

CHAPTER 4. ACTUAL REALIZATION









CHAPTER 5. LIST OF SENSORS AND ACTUATOR

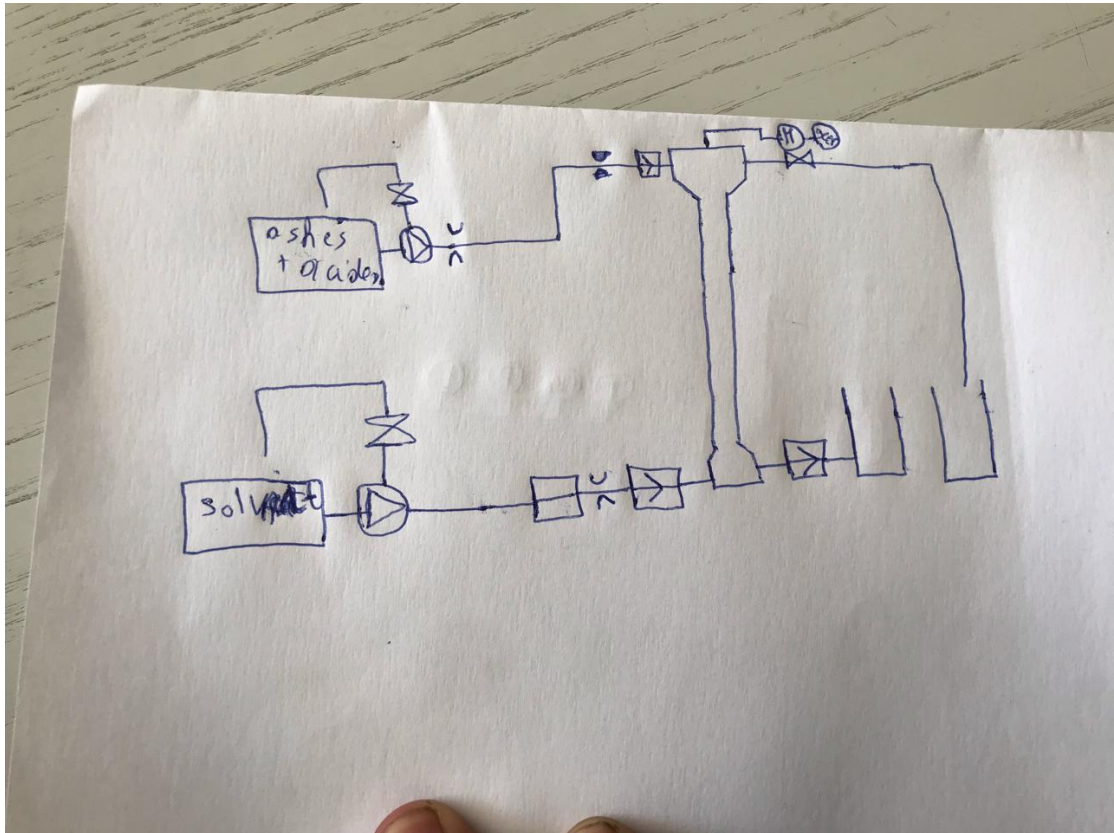

Requirements:

3 valves

Motor

Geer

2 Flow sensors

3 Check valve

CHAPTER 6. AUTOMATION

needed for automation: only 2 solenoid valves (for exits)

algorithms