

TEMO – STPP

The TEMO Solar-Thermal Power Plant Project



Source- BOSCH Rexroth, Hydraulic Controls brochure



Above: Solar Thermal Power Plant in Mojave Desert, California

مشروع محطة طاقة عن طريق الطاقة الشمسية الحرارية

شارك في الاستثمار لتطور الامة

Investment for Future

بِسْمِ اللَّهِ الرَّحْمَنِ الرَّحِيمِ

„Our profile is the combination of a cooperation structure with applied research institutes, the experience and the know-how of our engineers and the intercultural competence of our young international team“.



Welcome

The worldwide growth of economies creates an increasing demand for energy and fuel. On the other hand the demographic development both in Europe, where the working population is decreasing and in the North-African and Middle East region, where the amount of younger people who have a future working potential is increasing, it is necessary to find ways to offer future energy resources for Europe and the North-African and Middle East region. And in an increasing amount there must be found working possibilities for the growing up youth in the North-African and Middle East region especially now in background of the political changes in the region.

So it is very important to implement one of key technologies – energy producing technology – in this region on the one side and on the other side implementing a future energy resource for Europe when the conventional resources will be over and especially nuclear energy is not any more a desirable choice for European people after Fukushima accident.

So the TEMO-STPP project produces energy, which can be used by the producing country and also transported to Europe and on the other hand creates working possibilities for the young educated people in the North-African and Middle East region. And with the help of God, the Almighty, this will be a big effort for a better and peaceful future for the two neighbour regions Europe and North-Africa/Middle East.



Samir Mourad, Electrical Engineer
AECENAR President & TEMO e.K. CEO

What is a “Solar Thermal Power Plant” (STPP)”?

A solar thermal power unit uses rays of the sun to heat thermal oil through mirrors. Thus water turns into water vapor. The water vapor is then conducted into a turbine that activates a current generator. This generator produces electric current, which is injected into the power supply system. For night operation storage salt is being used that was heated at daytime. The STPP operates without any photovoltaic, which use resource silica. Thus this technology is 100% sustainable and does not spend any of our most precious resources. Furthermore it is a very good alternative for regions rich of sun's rays instead of conventional power stations, such as coal-fired and nuclear power stations.

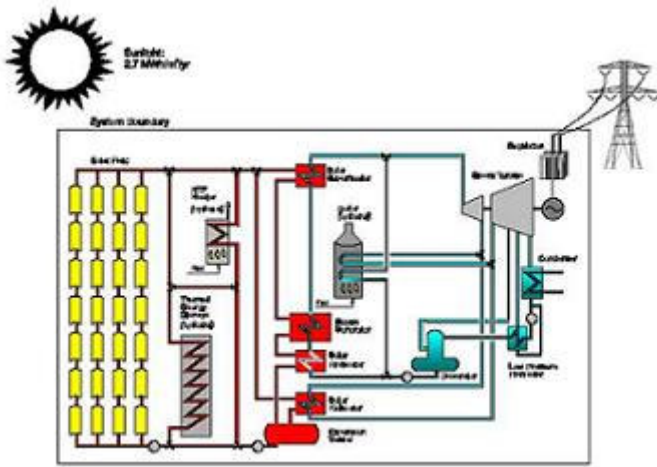

Block diagram of a solar thermal power plant



Solar collector array



Steam Turbine



Generator

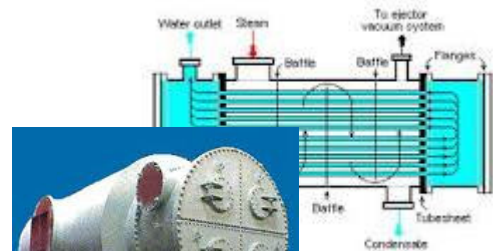

Condenser

Conventional Main Power Plant Elements which are Reusable from Out of Service Conventional Power Plants

Efficiency and financial risks

According to a study of the AECENAR member institute VaEf (Institute for Alternative Energy Research) which is based, among other things, on studies of the world bank in 1999, the estimated costs of such a unit will be starting at 2010 about 3-4 Cent a KWh. Thus such a unit is competitive.

The TEMO-STPP project

It is planned to install a 7 MW power station.

The STPP is going to be completed by the end of 2013, so God will.

To gain major investors, in cooperation with scientific institutes

(Assoc. for Alternative Energy Research (VaEf), Karlsruhe as well as the Institute for Nuclear Technology and Reactor Safety at the University of Karlsruhe) a model of the STPP as big as a table was installed.

For initial kernel team building a test rig with smaller than 500 kW is developed actually.

Time scale

	2004 - 2008	2008 – (planned) June 2012	(planned) July 2012 – December 2013
Activities	Studies and Pre-Development	Development of Test rig	Installing the 7 MW STPP in North Africa (Zawia/Lybia)
Partners	TEMO, VaEf (institute of AECENAR), KIT (Karlsruhe Institute of Technology (former name of KIT: University of Karlsruhe))	TEMO, AECENAR, KIT	TEMO, AECENAR, Lybian Solar Energy Company

Development of TEMO-STPP Test rig

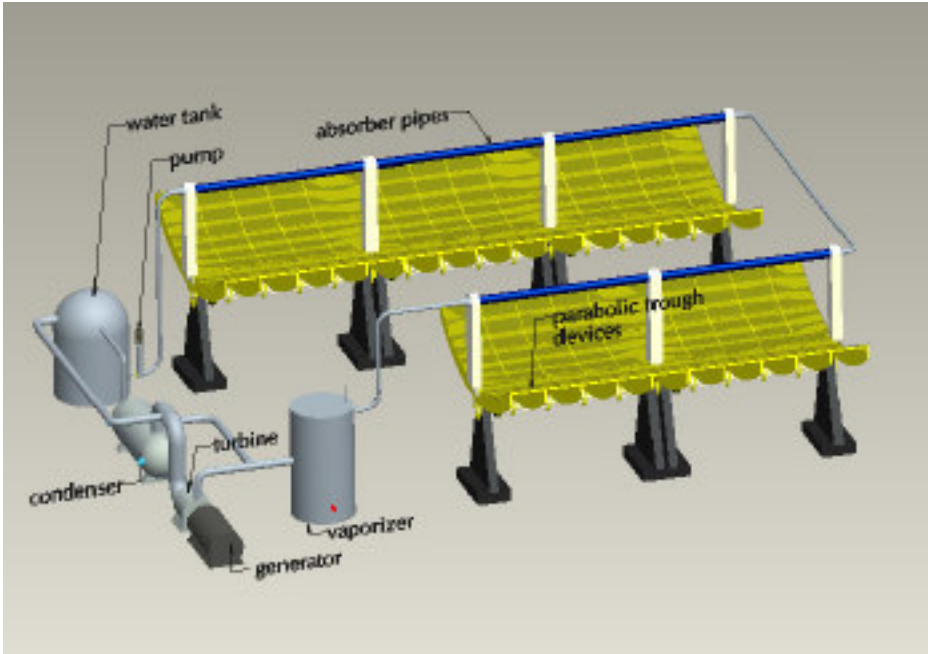

Process control system
Development with Siemens S7 technology



Construction of mechanical pieces with
CAD program ProEngineer



Solar vacuum pipe



Manufacturing of solar parabol panels



Connections between Europe and Middle East/North African Region



Actual Partners and Roles in the TEMO-STPP (Solar Thermal Power Plant) project

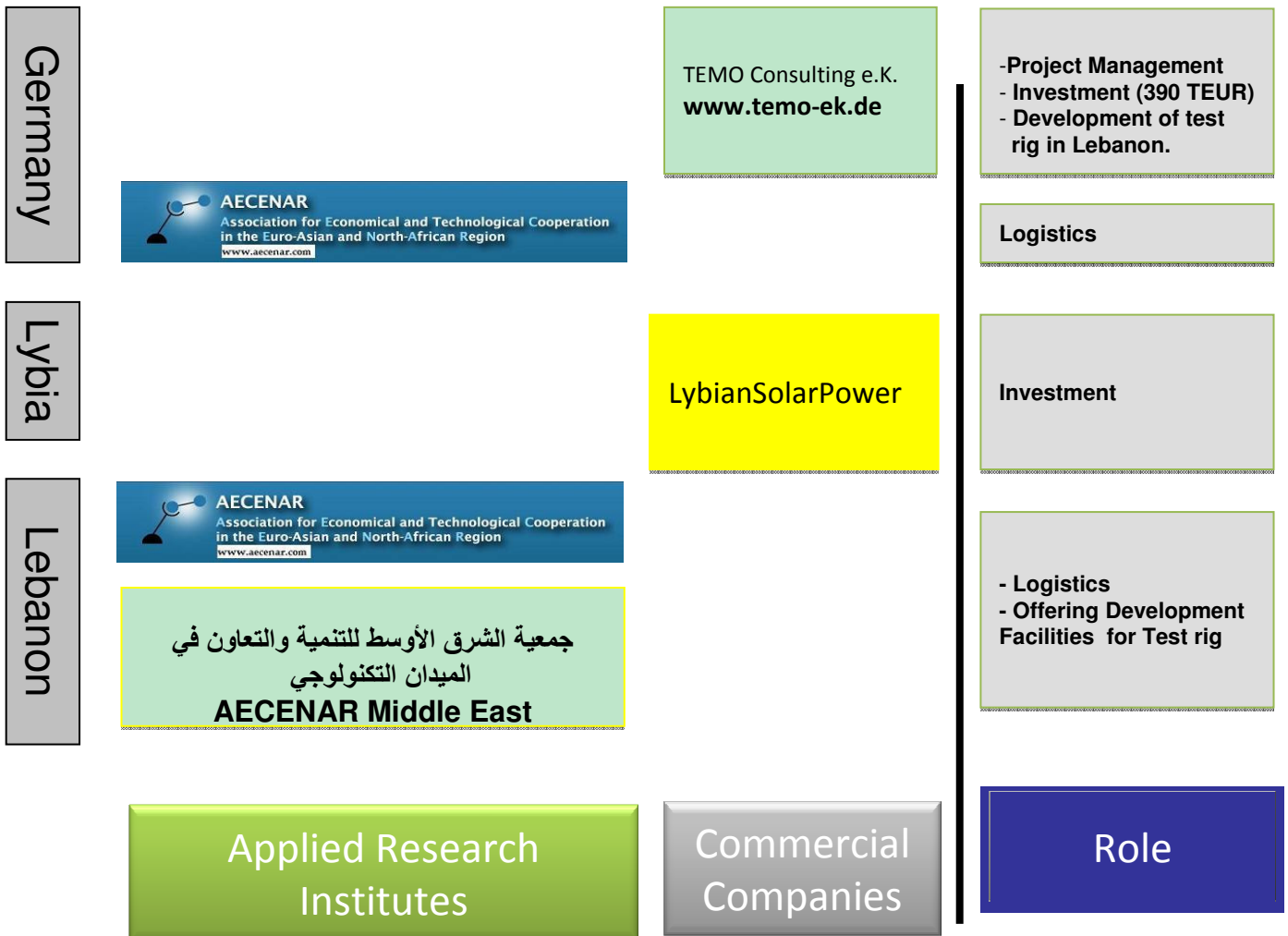

Next Steps Overview

July 2011 – June 2012

July 2012 – December 2013

Test rig phase

Installation in Zawia/Lybia

Task:
Installation of < 500 kW test rig

Time span: 12 months
Personnel: 4 engineers

Costs: 765.000 EUR

Task:
Installation of a 7 MW power plant in the Lybian Desert

Time span: 18 months
Personnel: 4 engineers, 50 technicians

Costs: 18 Mio. EUR

Amortization time: until 2028 insha Allah

Selling Price of 1 kWh: 7 EUR-Cent

TEMO-STPP (Solar Thermal Power Plant) project – Test rig phase
Planned working packages, costs, output

Task:
Installation of 200 kW test rig

Time span: 12 months
Personnel: 4 engineers

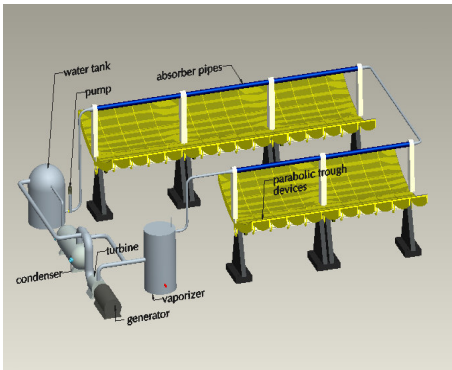

Material Costs

Pump, pipes, ...	5.000 EUR
Solar field	10.000 EUR
Steam production (by incineration)	40.000 EUR
200 kW Turbine&Gen.	150.000 EUR
Condensor	20.000 EUR

To be paid until 15 Dec 2011 by LybianSolarPower

Personnel Costs

Staff
 Samir M. (Project Management)
 Abdulfattah A. (Integration)
 Mohamed G. (S7 Control System)
 Said Elm. (User Interface, ...)

4x12 man months = 480.000 EUR
 (4x12x1000 EUR= 48.000 EUR to be paid until 31 march 2012, rest is investment from TEMO)

Using AECENAR Facility

12 x 1000 EUR = 12.000 EUR
 (to be paid by LybianSolarPower until 31 march 2012)

Total costs: 765.000 EUR

-Small Solar thermal / conventional (Incineration) 200 kW combination Power Plant

-Trained Lybian personnel: experts which are able to lead the next stage (Lybian desert 7 MW STPP)

Activities ...

Costs

Output / Win

TEMO-STPP (Solar Thermal Power Plant) project – Installation in Zawia/Lybia

Time span:

**18 months
(Aug. 2012
– Dec. 2013)**



Material

7 MW Turbine&Generator	1.000.000 EUR
Heat exchanger, condensor, Pipes, pumps, ...	200.000 EUR
400m x 400m solar collector field	100x30x5.000 EUR =15 Mio. EUR

Personal

Staff

Project Management & Leadership

Samir M.
Abdulfattah A.
Mohamed G.
Said Elm.

About 50 technicians and workers

Personnel costs: **1.200.000 EUR**

Total installation cost: about 18 Mio. EUR

7 MW Solar thermal Power Plant

Operated and lead by experts from Lybia and neighbour countries

**Activities:
Installation of the
Power Plant**

Costs

Output / Win

TEMO Consulting e.K.

Haid-und-Neu-Strasse 7
76131 Karlsruhe, Germany

Email: info@temo-ek.de
Website: www.temo-ek.de

AECENAR e.V.

Haid-und-Neu-Strasse 7
76131 Karlsruhe, Germany

Email: info@aecenar.com
Website: www.aecenar.com

For contact:

Samir Mourad

Phone (Office Lebanon) ++961(0)6 921318

(Mobile Lebanon) ++961 71 935 938

(Office Germany) ++49 (0)721 9658 567

(Mobile Germany) ++49 (0)176 4039 2038

Email: samir.mourad@temo-ek.de