



AECENAR

Association for Economical and Technological Cooperation
in the Euro-Asian and North-African Region

www.aecenar.com



طاقة الشمال

North Lebanon Alternative Power

www.nlap-lb.com

Heavy Metals Recycling Unit for NLAP-IPP Demonstration Plant

NLAP-WEDC (Waste to Electricity Demonstration Cycle)

Author:

Maysaa Kamareddine

Last update: 6.8.18



North Lebanon Alternative Power
www.nlap-lb.com

بِسْمِ اللَّهِ الرَّحْمَنِ الرَّحِيمِ



Tripoli, 11. April 2018

PhD thesis: Optimal heavy metals recovery from waste bottom and fly ashes from waste incineration

The most commonly encountered toxic heavy metals in wastewater:

- Arsenic, Lead, Mercury, Cadmium, Chromium, Copper, Nickel, Zinc.
- **Sources:** Industrial sources: e.g. Printed board manufacturing, metal finishing and plating, semiconductor manufacturing, textile dyes, Street runoffs, Landfills
- **Effects:** Many heavy metals are essential trace elements for humans, animals and plants in small amounts. In larger amounts cause acute and chronic toxicity.

Conventional Mixer Settler

BATEMAN PULSED COLUMN

Working packages:

1. Development of a basic liquid-liquid extractor for Ni, Cu, CO, Zn, Cd, Pb, Hg.
2. Optimization of process in pulsed column or similar column with different diluent pairs

Contact: Eng.Samir Mourad ,Samir.mourad@aecenar.com,mob:+96176341526

Contents

1. Introduction.....	4
2. The phase equilibrium of ternary mixtures.....	5
a) The partition coefficient.....	5
b) The ternary diagram.....	5
c) The demixtion.....	6
d) Solvent separation.....	7
3. Countercurrent extraction.....	8
e) The principle.....	8
f) the material balance.....	9
g) The existence of a pole P.....	9
h) Remarks.....	10
4. Extractant Types.....	11
5. Design of pulsed column.....	12
i) type of metal.....	14
6. EXPERIMENTS.....	14
j) feed solution.....	14
k) dimension of the extraction column.....	14
7. Design.....	17
l) Column.....	18

Figure 1 : principle of a separation stage by obtaining a balance.....	4
Figure 2 : ternary diagram.....	6
Figure 3 : Isothermal and isobaric demixing curve.....	7
Figure 4 : Representation of a ternary system with limited miscibility	8
Figure 5 : diagram of countercurrent column	8
Figure 6 : Graphical construction of theoretical floors.....	10
Figure 7 : pulsed column	13
Figure 8 : overview of RDC column.....	17
Figure 9 : top and side face of column	18
Figure 10 : rotation axis	19
Figure 11 : rotor perforated (20 perforation,)	19
Figure 12 : 10 rotor spaced 15 cm	20
Figure 13 : stator (10 pieces) with rotor	20
Figure 14 :Distribution of rotors and stators	21
Figure 15 :upper and bottom decanter (200 mm of radius, hight 300 mm.....	23

Table 1 :list of parts that formed a system of extraction	24
--	-----------

1. INTRODUCTION

Solvent extraction, or liquid-liquid extraction is a separation technique isothermal in a heterogeneous liquid medium.

The method is based on the existence of a difference in the solubility of a substance in two immiscible liquids. The process has three steps, as shown in Figure 1:

- Mixture of the two immiscible liquids, one of them containing the solute,
- Obtaining physico-chemical equilibrium, leading to demixing,
- Separation of the two new liquid phases obtained based on the difference of densities.

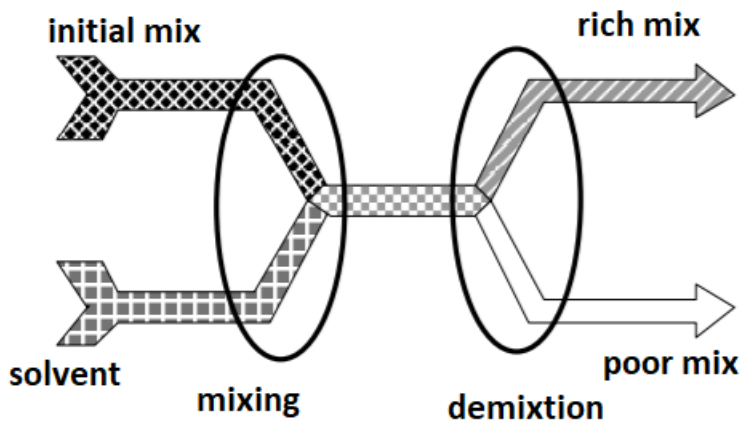

Figure 1 : principle of a separation stage by obtaining a balance

Practically, the feed solution F containing solute B dissolved in the diluent A is contacted with the solvent S. The solute B, generally more soluble in the solvent than in the diluent, passes from the solution in the solvent, the solvent enriched in solute is the extract E while the diluent depleted solute is the residue (or raffinate) R. These indications can be found in FIG.

The passage of solute B from diluent A in solvent S takes place as long as the equilibrium physico-chemical is not reached.

So that the driving force of transfer remains almost constant, the two liquids feeding the column flow against the current.

In order to transport the material as quickly as possible, the area of the transfer surface is increased by various artifices. These objectives can be obtained in a column.

2. THE PHASE EQUILIBRIUM OF TERNARY MIXTURES

A) THE PARTITION COEFFICIENT

A substance B placed in contact with two partially miscible solvents or immiscible S and A is distributed unequally between the two phases that are formed when the physicochemical balance is reached. The ratio of B concentrations in these two phases is the partition coefficient m .

B) THE TERNARY DIAGRAM

At equilibrium, these biphasic systems are trivariant. At pressure and temperature constants, they can be represented in a system of triangular axes. The equilateral triangle has the advantage of allowing an equivalent representation for all the constituents. The right triangle has the advantage of being able to expand the scale of one of the axes. It is often interesting to limit the plot to the "useful" part. Each vertex of the triangle represents a pure component. The solute content B, in solvent S and diluent A is expressed in mol%, mass, volume, etc ... and is obtained by a suitable projection on the axis chosen as shown in Figure 2.

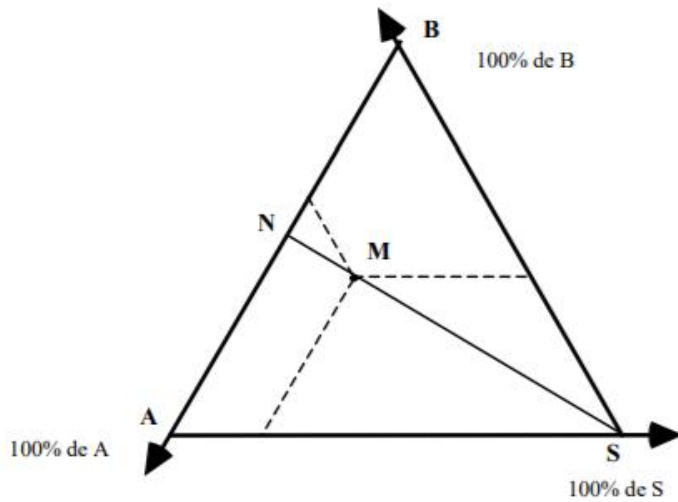

Figure 2 : ternary diagram

It is easy to demonstrate that the quantity of S and the quantity of the mixture N are in a ratio of the lengths of the MN and MS segments (rule of the lever arm) and that the quantities of two components are in the ratio of projections of the segments on the binary axis corresponding.

Conversely, if the mixture N is added a mass of solvent S, the ternary mixture result is represented by the point M on the line NS such that:

$$\frac{\text{mass of N}}{\text{mass of S}} = \frac{MS}{MN}$$

C) THE DEMIXTION

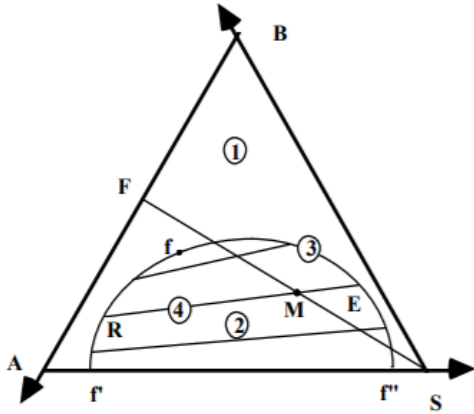

Figure 3 : Isothermal and isobaric demixing curve.

In a ternary system with limited mutual solubility zone (1) stable states, characterized by a complete miscibility, is separated from the zone (2) unstable states constituting the miscibility gap or diphasic zone, by the solubility isotherm (3) or line "Critical" or demixing curve or equilibrium curve or saturation curve.

Within the miscibility gap, no mixture can exist indefinitely:

any system whose overall composition is represented by point M is divided into two composition phases R and E, points at the intersection of the equilibrium line (4) or conodal RME and the demixing curve $f f f''$. At the critical point f the two phases in balance have the same composition.

D) SOLVENT SEPARATION

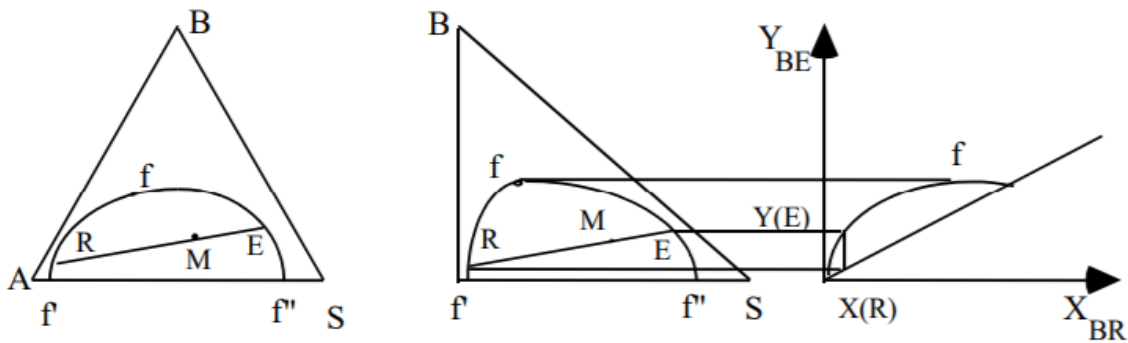

Figure 4 : Representation of a ternary system with limited miscibility

In the zone of total miscibility no separation can take place. However, if starting from an initial mixture F, by the addition of the solvent S, a system whose composition is global M lies within the miscibility gap, which separates into two phases R and E. Phase R, rich in diluent A is the raffinate, while phase E, rich in solvent S, constitutes the extract.

In general, the concentration of solute B in the raffinate is designated by x and in the extract by y . It is then possible to draw the distribution curve or equilibrium curve which represents y in terms of x .

3. COUNTERCURRENT EXTRACTION

E) THE PRINCIPLE

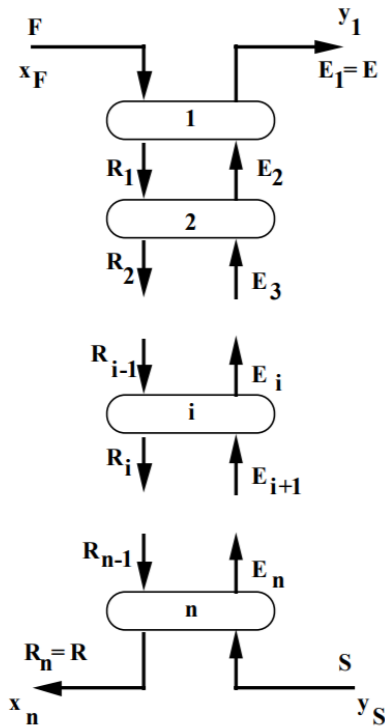

Figure 5 : diagram of countercurrent column

F) THE MATERIAL BALANCE

The writing of the material balance makes it possible to know the composition of the global system and of each of the subsystems (stages).

Balance sheet on the column:

$$\text{Global: } m_F + m_S = m_E + m_R = m_M$$

$$\text{Solute B: } m_F x_F + m_S y_S = m_E y_1 + m_R x_n = m_M x_M$$

This system of two equations with eight unknowns can be solved if six variables are otherwise known. In practice m_F , m_S , x_F and $y_S (= 0)$ are imposed. By fixing two other variables, for example x_n and m_R , this system of equations can be solved.

Moreover, the combination of these relationships makes it possible to determine the position of the point M in the ternary diagram. Graphically, F and S determine M. The point M is both on the FS and ER lines. R (R_n) being known, E (E_1) is obtained by the intersection of RM and the demixing curve. At point E_1 the conodal matches R_1 .

Balance sheet on the stage i:

$$\text{Global: } m_{R_{i-1}} + m_{E_{i+1}} = m_{E_i} + m_{R_i}$$

$$\text{Solute: } m_{R_{i-1}} x_{i-1} + m_{E_{i+1}} y_{i+1} = m_{E_i} y_i + m_{R_i} x_i$$

G) THE EXISTENCE OF A POLE P

The writing of the overall balance successively for the column and for each of the floors allows to show the existence of a pole P through which all $R_i E_{i+1}$ lines pass.

$$\text{Column: } m_R - m_S = m_F - m_E = \text{Cte} = m_P$$

The PRS and PFE points are aligned.

The FERS points being known, P is determined graphically.

Stage 1 : $m_{R1} - m_{E2} = m_F - m_E = m_P$

PR1E2 points are aligned. R1 being known, point E2 is in turn.

Step by step, it is possible to write:

Floor i: $m_{Ri} - m_{Ei+1} = m_F - m_E = m_P$

The points $PRiEi+1$ are aligned and the point Ri is known by the graphic construction

previous point, the point $Ei+1$ is determined.

Gradually, all the points Ri and Ei are determined.

The construction stops when the right $PRnS$ goes through R or "exceeds" R.

Each line $RiEi$ constitutes a theoretical stage.

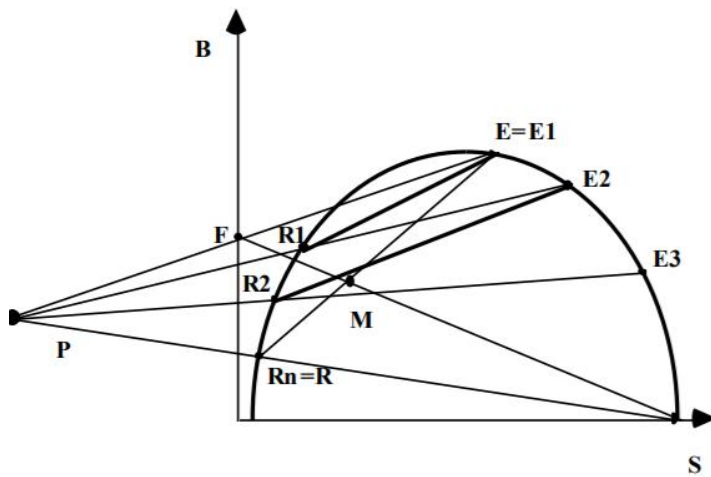

Figure 6 : Graphical construction of theoretical floors

H) REMARKS

The previous graphical construction is easier if on the same graph the demixing curve and the operating curve.

If an operating line passing through P was confused with an equilibrium line E_iR_i it then an infinite number of theoretical stages would be required. The ratio of the mass of solvent to that the power supply would then be the minimum usable to effect the separation. In practice we consider the equilibrium line passing through F as confused with the straight line passing through P. The intersection of the lines FS and $E_{1min}R_n$ gives the point M_{min}

hence the value of the ratio $(m_S / m_F)_{min}$.

The choice of the value of the solvent rate $p = m_S / m_F$ is done by taking:

- a) a value of m_S / m_F greater than $(m_S / m_F)_{min}$,
- b) a value of the extraction factor

$$\varepsilon = m_p = m \frac{m_E}{m_R} = \text{partition coefficient} \frac{\text{mass flow of extract}}{\text{mass flow of raffinate}}$$

between 1,2 & 2.

4. EXTRACTANT TYPES

Oxime based extractants for copper are largely based on salicyaldoximes which have been modified with one of three modifier types. Examples of the three main extractant types currently in use are:

1. LIX® 984N

A mixture of 2-hydroxy-5-nonylacetophenone oxime and 5-nonylsalicylaldoxime in a high flash diluent. The acetophenone oxime modifies the aldoxime and also performs as an extractant in its own right.

2. Acorga® M5640

5-Nonylsalicylaldoxime modified with an ester, 2,2,4-Trimethyl-1,3-pentanediol Diisobutyrate (TXIB) in a high flash diluent.

3. LIX® 622N

5-Nonylsalicylaldoxime modified with tridecyl alcohol in a high flash diluent.

Each of the extractants marketed by the major chemical suppliers has been designed for a specific type of PLS with regard to pH and copper tenor. Used under the conditions for which they were designed they all deliver very similar copper net transfer values. The physical properties of the various types of extractant do show some differences with the aldoxime/ketoxime mixtures such as LIX984N showing lower entrainments and greater tolerance to crud than the other reagents when treating some types of PLS. The vol% concentration of the commercially available extractants is limited by organic viscosity constraints to about 30-33% and this means that the maximum net transfer of copper will be about 10g/l. For leach solutions containing significantly higher copper tenors than this the throughput O/A ratio will have to be increased above 1.0.

5. DESIGN OF PULSED COLUMN

the figure shows a pulse column stripping the desired component from an organic phase consist of a vertical riser, **poppet valves**, v1 which admits air pressure to the pulse leg and v2 which exhausts air from the pulse leg, the rotating cam and drive mechanism which alternately close and opens v1 and v2, the air reservoir which smooths out fluctuations in air pressure supplied in v1 and the pressure regulating valve which permits adjustment of air pressure in air reservoir.

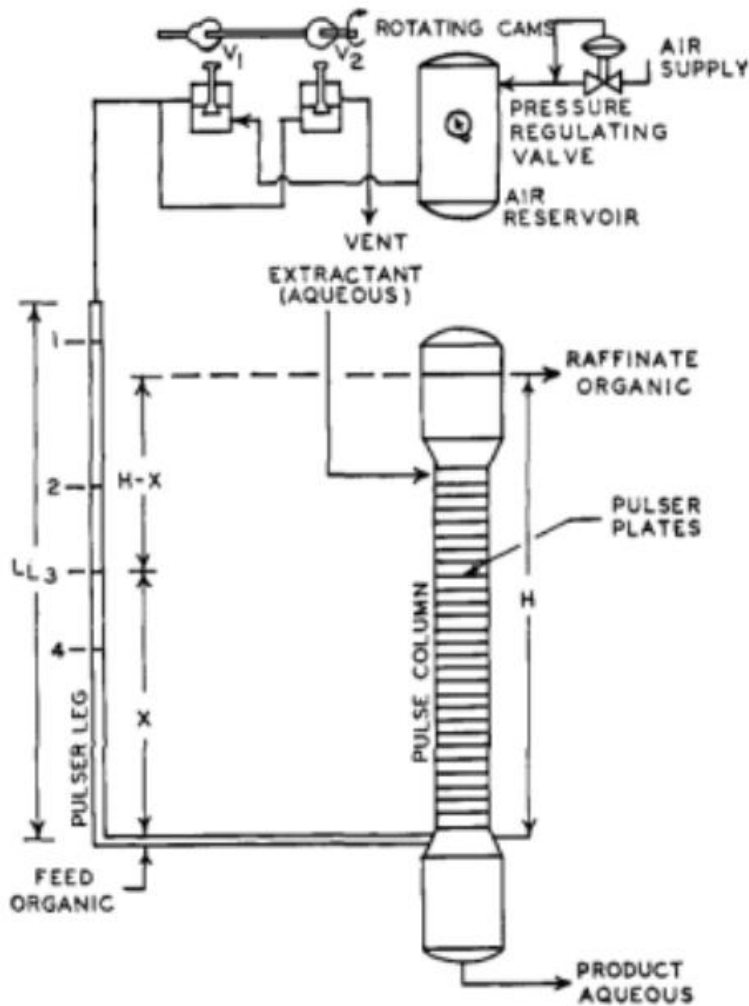

Figure 7 : pulsed column

if the fluid in the column and pulse leg are permitted to reach hydraulic equilibrium (valve 2 open), the fluid level will be reached position 1 in the leg with the fluid level maintained at the overflow point in the column. air pressure is now set and the cam started rotating. When v_1 is open, v_2 is closed which alternately admits and releases air into and from the pulse leg. After equilibrium is reached in the system, the fluid in the leg will reach an average position 3 and will oscillate between points 2 and 4. air pressure forces the fluid down from 2 to 4 while the hydraulic head differences between the column overflow and fluid in the leg force the fluid in the leg back from 4 to 2. This interchange of fluid between the pulse leg

and column provides the pulse action required in the column .Operating ranges usually encountered in amplitude area from 0.4 to 1.25 inches in the plate section of the column at frequencies from 40 to 100 cycles in minute . the poppet valve and motor are arranged with flange disconnects and electrical plugs-in for ease in replacement of unit needing maintenance.This pulsers are fitted with rotary and liquid sensing devices which close a safety in the event either sensor signals.

I) TYPE OF METAL

the construction of the column requires a metal that is resistant to corrosion and consequently the destruction. We can have mentioned some metals such as stainless steel that is the best un this case.

6. EXPERIMENTS

J) FEED SOLUTION

Assuming that the amount of waste incinerated to treat equal to 150 kg.

the amount of concentrated nitric acid required for leaching is 150kg for leaching in 24 h .

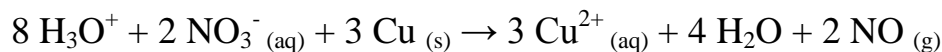

Noting that we want to use pure nitric acid concentrate to avoid any corrosion of stainless steel. according to previous studies, 1 kilogram of bottom ashes contains 1 g of copper metal.

K) DIMENSION OF THE EXTRACTION COLUMN

The amount of feed solution that considered as aqueous solution at 90°C (3h)is about 300L.

A column of 40 cm radius is suitable in this case.

in most cases found limited to operations where:

- the density differences between the carriers is higher than $30 - 50 \text{ kg/m}^3$
- the volumetric phase ratio between dispersed drop phase and continuous phase is in the magnitude of $0.5 < < 5$
- the number of theoretical stages NTS 10

Column	Length (cm)
High	250
Radius	40
Sheet of stainless steel	2500×125

Characteristics of the RDC column

Column height / cm	Column active height / cm	Inner column diameter / cm	Inner stator diameter / cm	Outer rotor diameter / cm	Compartment height / cm	Number of compartment in active region
150	60	9.1	6.1	4.55	3.2	21

The first and second critical rotor speeds could also be defined based on breakage probability: the first critical rotor speed for a drop with particular size defines as the rotor speed at which the drop breakage starts. In fact, before the first critical rotor speed, the probability of break up for a drop with specific size is zero. Moreover, the second critical rotor speed (for a drop with a particular size) is a rotor speed at which the probability of breaking that drop is equal to 1³

The breakage probabilities *versus* rotor speed for mentioned chemical systems using glassy nozzles with different inner diameters (1.2 and 2.5 mm) to form various drop sizes by adjusting the Q_c/Q_d ratios and continuous phase heights are presented in next figure Regarding to these graphs, the drop breakage increases by increasing the volumetric phase ratio that leads to decrease of the first critical rotor speed. It could be justified with increasing this ratio, the drag forces between the continuous phase and dispersed drops increase results to enhance the probability of drop break up due to collision with the rotors. Mother drop diameter is effective on first critical rotor speed such that the nozzle with larger internal diameter produces larger mother drops with an increase in the probability of break up results to decrement of first critical rotor speed. Increasing the height of continuous phase led to increase of resistance against to upward motion of drops thereupon increment of the break up probability and decrement of the first critical rotor speed. Based on

experimental results, the first critical rotor speed for considered chemical system should be 230 rpm.

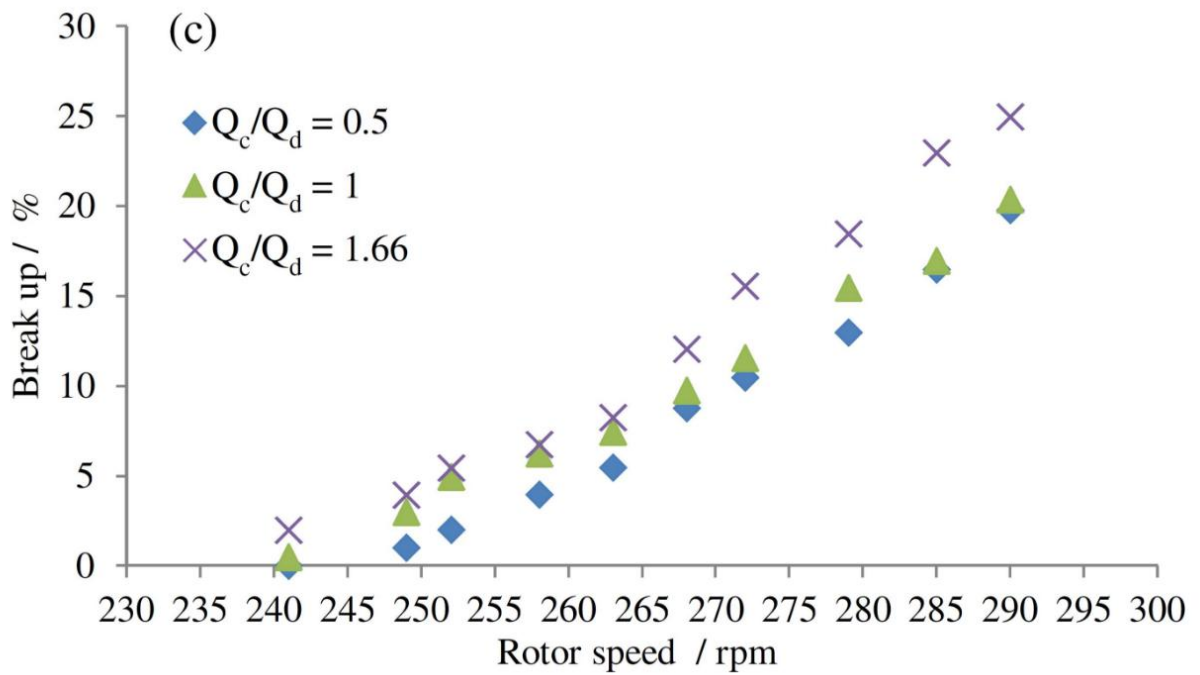
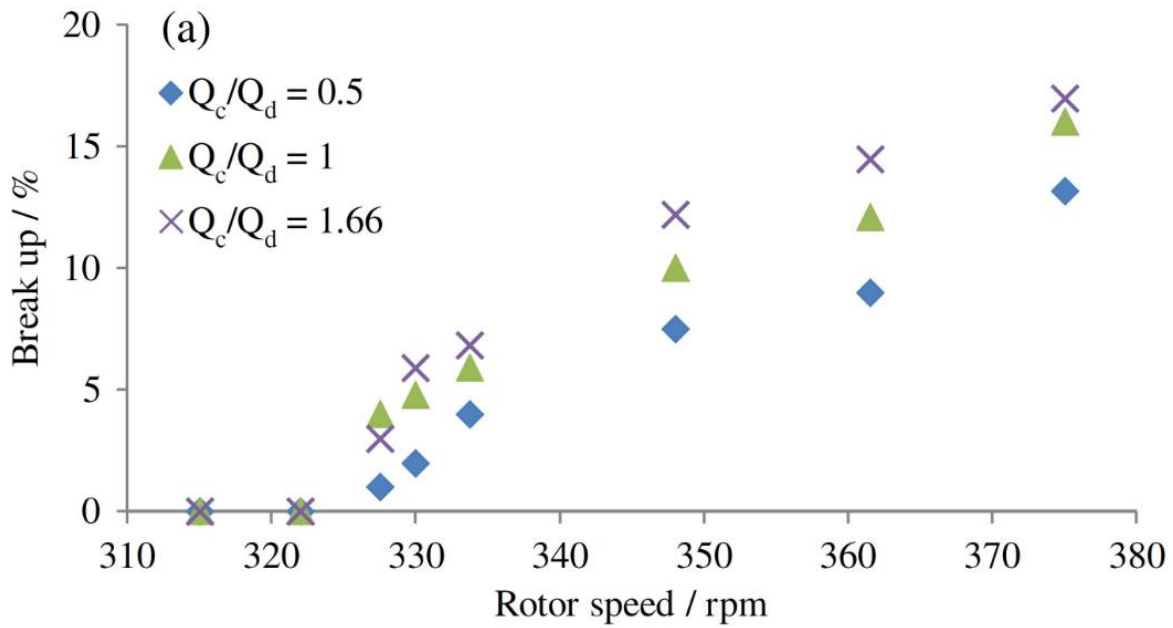

7. DESIGN

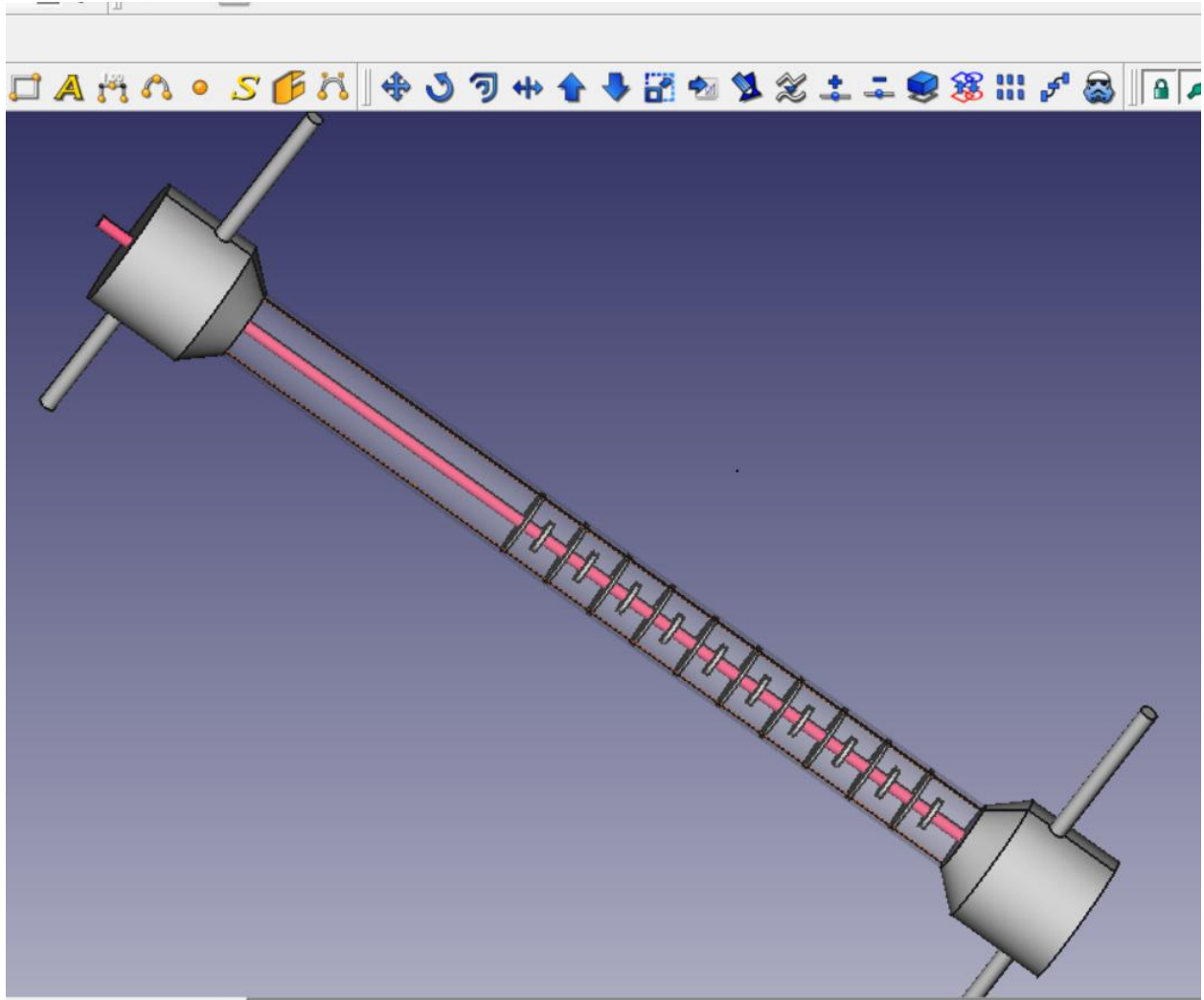

Figure 8 : overview of RDC column

L) COLUMN

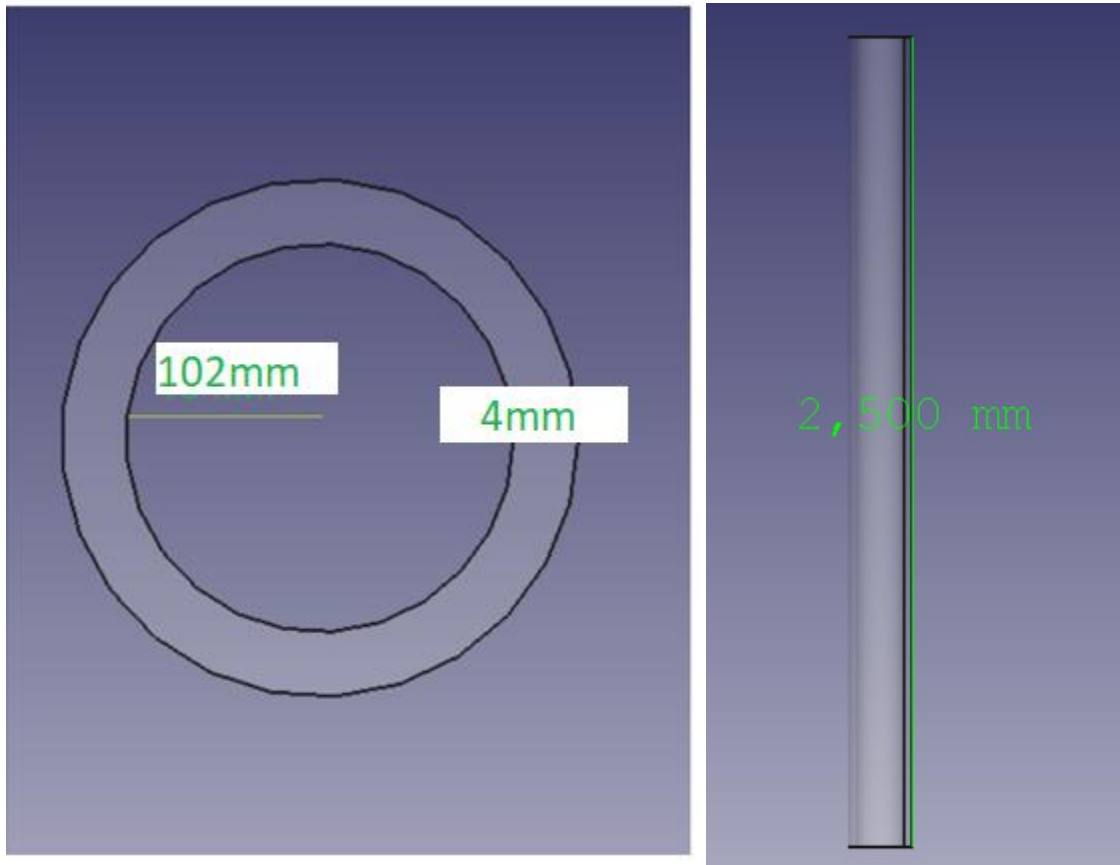

Figure 9 : top and side face of column

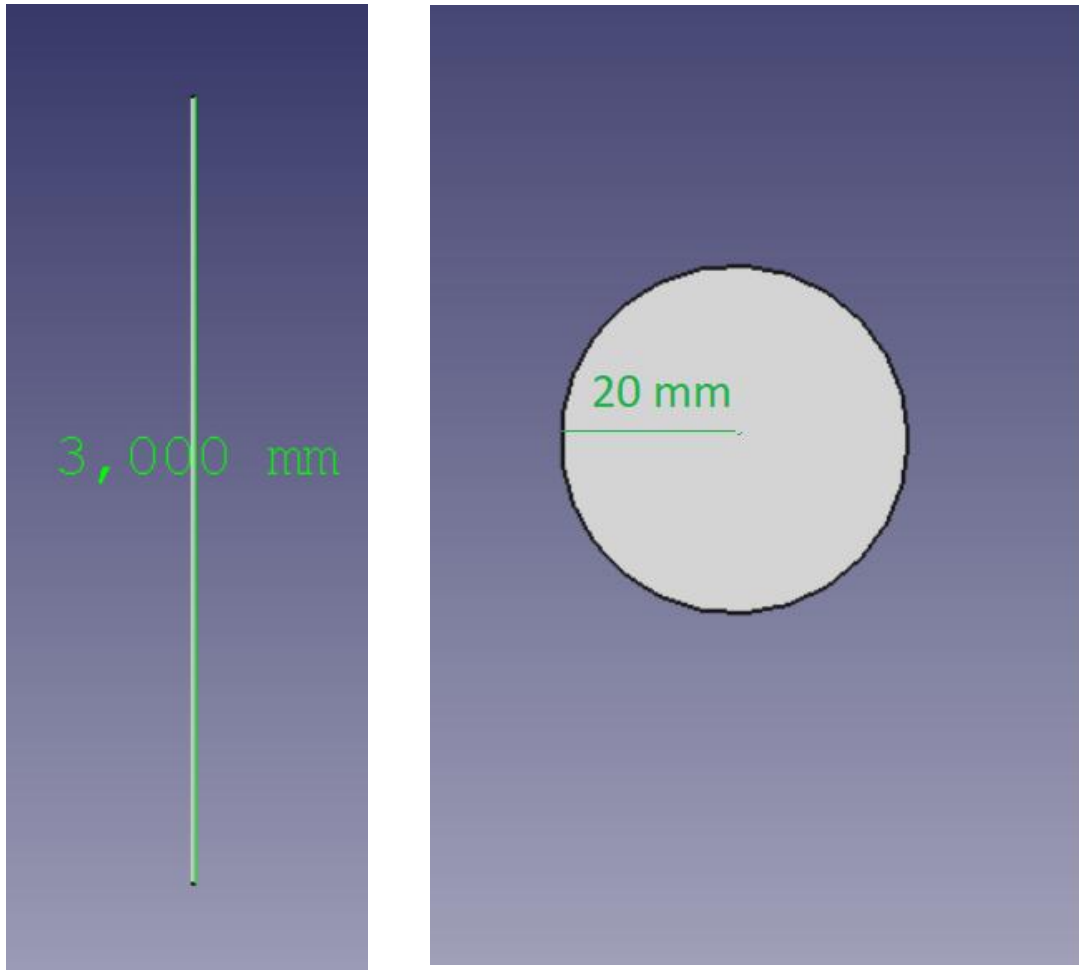

Figure 10 : rotation axis

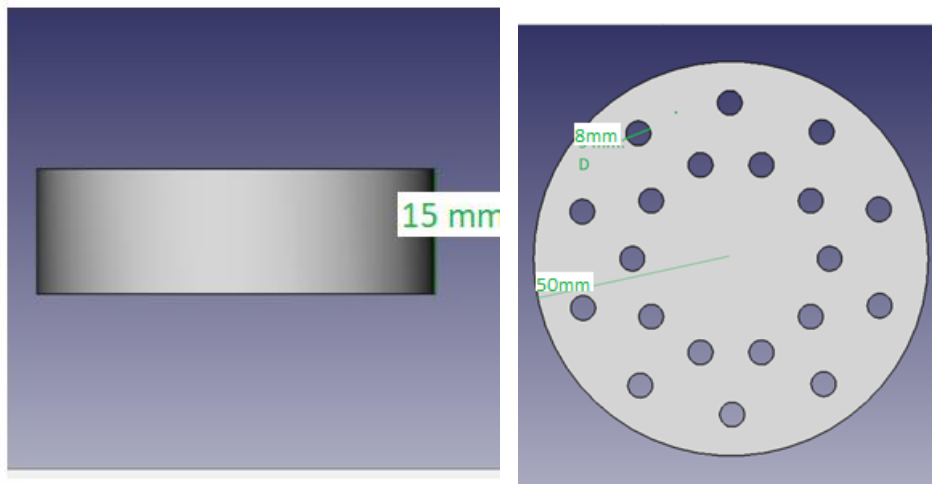

Figure 11 : rotor perforated (20 perforation,)

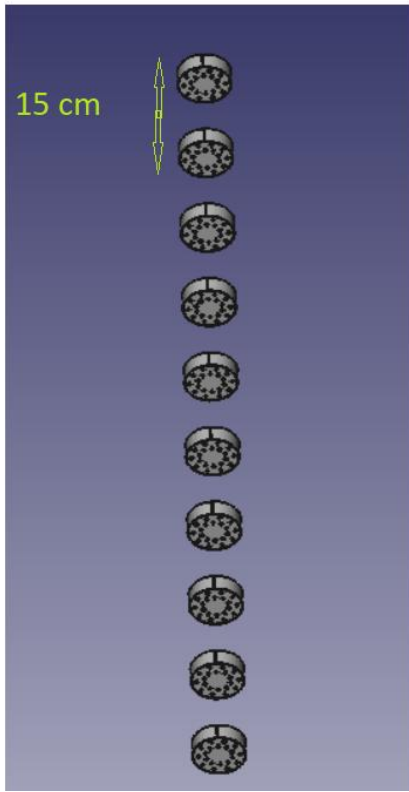

Figure 12 : 10 rotor spaced 15 cm

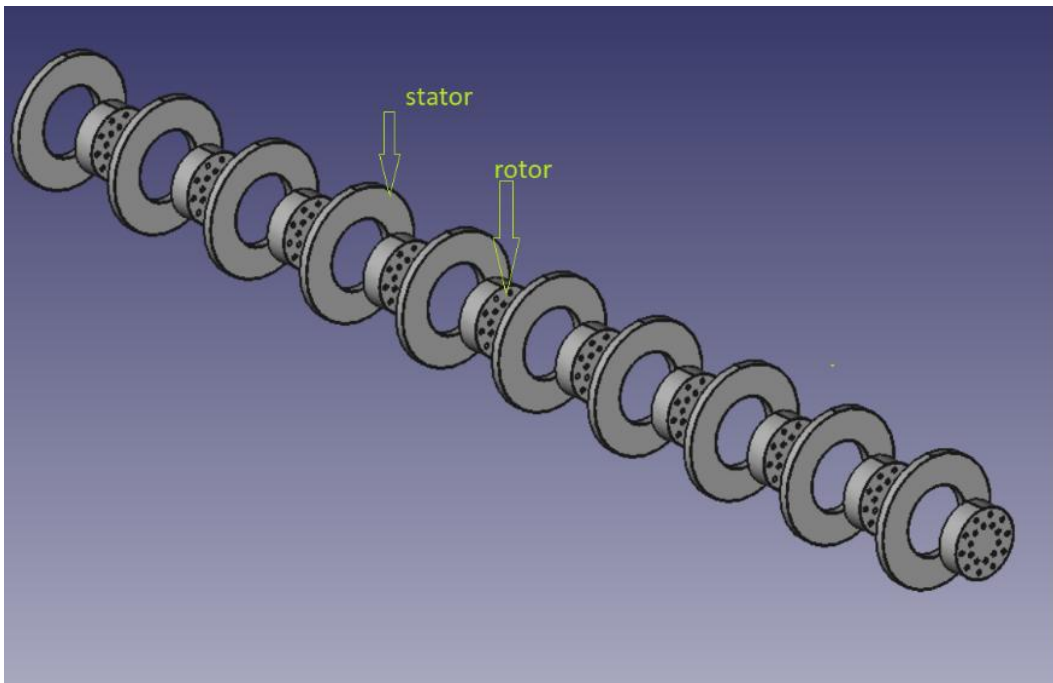

Figure 13 : stator (10 pieces) with rotor

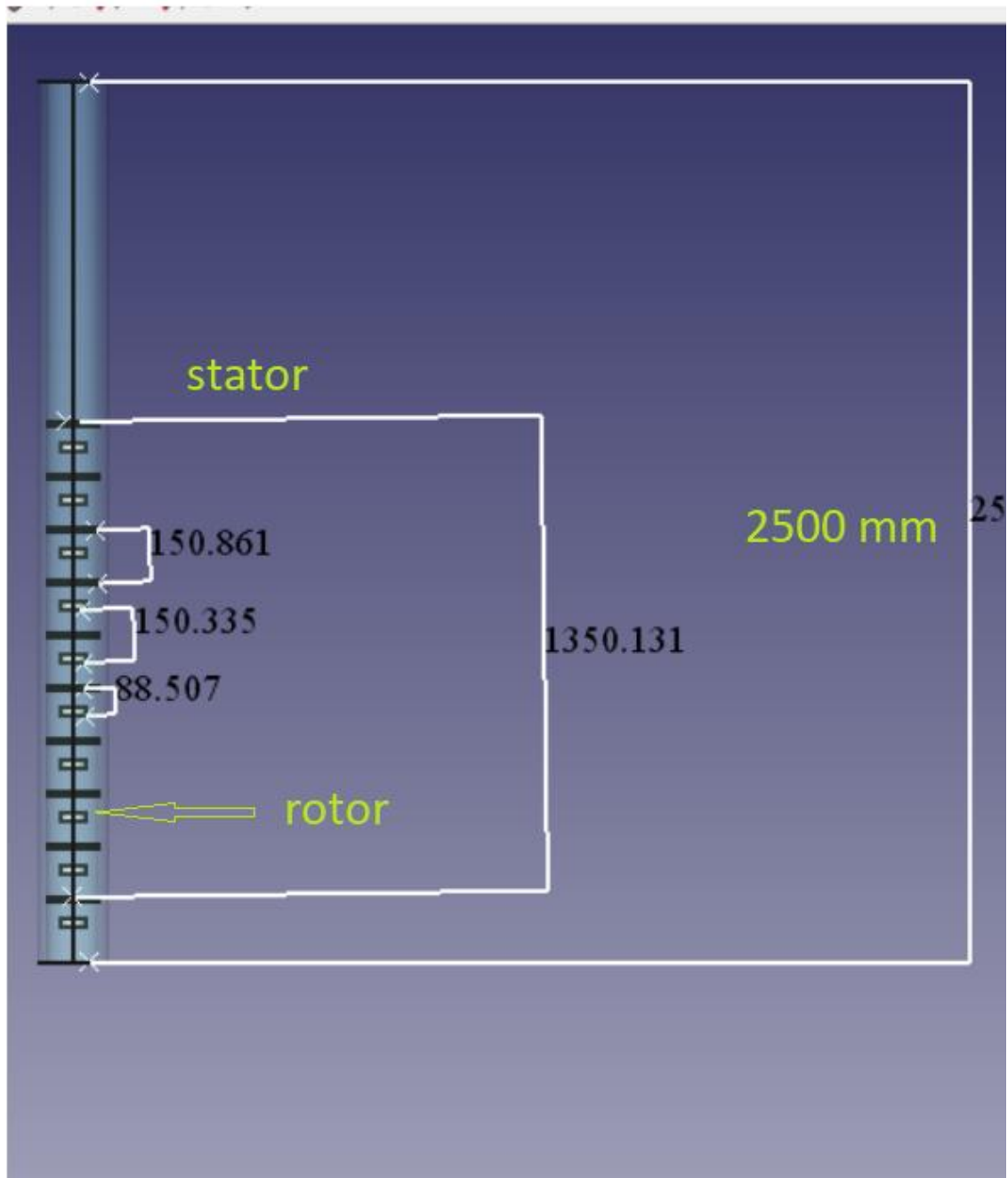
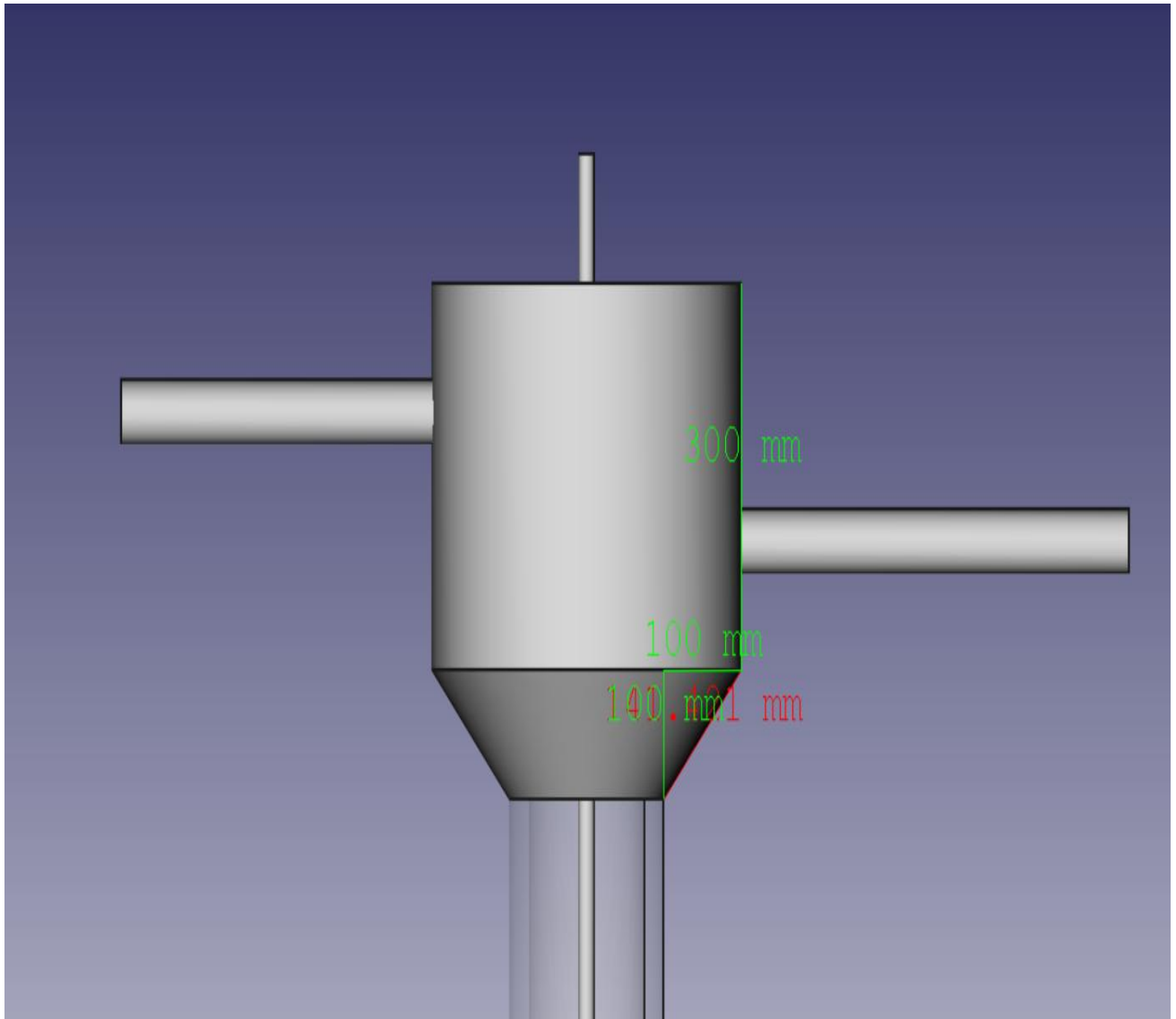

Figure 14 :Distribution of rotors and stators



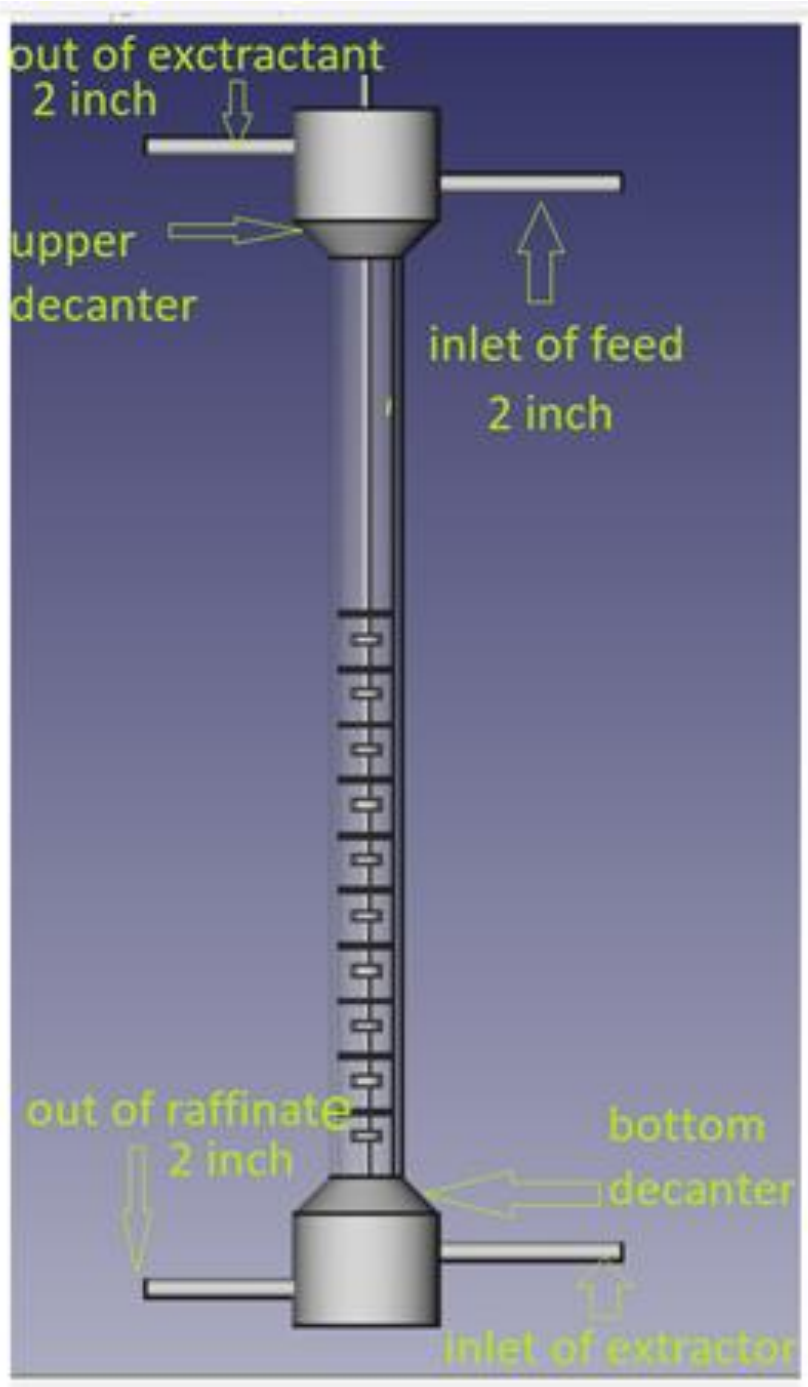

Figure 15 :upper and bottom decanter (200 mm of radius, hight 300 mm
Cone $r_1=200\text{mm}$, height 100 mm)





parts	Freecad files
Column	 column06082018.FCStd
Rotation axis	 column wih rotation axis140818.FCStd
Stator	 stator 06082018.FCStd
rotor	 rotor 06082018.FCStd
System	 FINAL DESIGN OF COLUMN140818.FCStd

Table 1 :list of parts that formed a system of extraction

Parts	Dimension	
Covering column	Internal diameter:220 mm Outside diameter:212 mm	
Columns that carry stators	Number:3 Diameter:4 mm Height 2500 mm	
Stator	Number:10 Internal diameter:120 mm outside diameter:204 mm Height:15 mm Spaced:150 mm	1 half of pate 1m*2m

Decanter (cylinder+cone)	Number :2 Radius 1:110 mm Radius 2:200 mm Height: 100 mm -Cylinder: Height :300 mm Diameter:400 mm	2 plate 1m*2m
Rotation axis	Diameter :40 mm, height:3000 mm	
Rotor perforated(20 punch ,D=8 mm)	Number :10 Internal diameter:40 mm Outside diameter:100 mm Height:15 mm Spaced :150 mm	1 half of plate 1m*2m